



- Colors compliment pinta acoustic's ceiling tiles
- Double web construction for durability
- Versatile and easy to install

pinta Ceiling Grid System

Product Information

Now you can have a ceiling grid system that blends beautifully with pinta's or standard ceiling tiles. pinta's Ceiling Grid System is offered in colors that complement the Hypalon® coating or natural finish of our HARMONI, CONTOUR® and WHITELINE® Ceiling Tiles as well as our SQUARELINE® Metal Ceiling Tiles, BIOLINE® Wood Ceiling Tiles, PHONSTOP™ Ceiling Tiles and SONEX® Clean Ceiling Tiles. Standard colors include white, almond, grey, satin chrome and black. Custom colors are also available.

Our commercial-quality ceiling grid system features standard $\frac{15}{16}$ " capped grid face and a double web design for added strength. It is also easy to install.

Part Selections

- 8' Main runners
- 4' High profile cross-tees
- 2' High profile cross-tees
- 8' Wall angle moldings
- 12' Main runners and wall angle moldings are available special order

Features and Benefits

- Intermediate ASTM load-bearing capabilities
- Main runners have non-directional bayonet couplings
- Integral cross-tee end tabs for positive locking and easy disassembly
- Stepped-end cross-tee design resists twisting and provides finished appearance
- Components feature hot-dipped galvanized steel web and capped face for superior corrosion resistance
- All components – main runners and high-profile cross-tees – are manufactured from the same metal for superior strength and stability
- Meets or exceeds building code requirements including Seismic Zones 0-2
- Apply in any area where a drop-in ceiling is desired

White ceiling grid system supporting
WHITELINE® Ceiling Tiles



White ceiling grid system supporting
HARMONI Ceiling Tiles



Satin chrome grid system supporting
SQUARELINE® Metal Ceiling Tiles



Colors

- White
- Almond
- Grey
- Satin chrome
- Black
- Custom colors are available
(minimum quantities may apply)

Materials

- Hot-dipped galvanized steel
- Painted face
- Sturdy double-web construction
- Standard 15/16" capped grid face

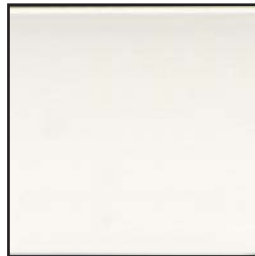
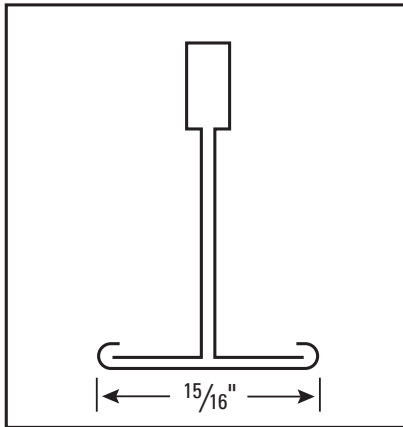

White



Almond



Black



Grey



Satin Chrome

Specifications

Product	Length	Nominal Dimensions	
		Height	Face
Main Runners	8'	1 1/2"	15/16"
Cross-tees	2'	1 1/2"	15/16"
	4'	1 1/2"	15/16"
Wall Moldings	8'	7/8"	7/8"

Other Products

pinta acoustic, inc. manufactures a broad range of acoustical materials including:

- CONTOUR® Ceiling Tiles
- HARMONI Ceiling Tiles
- WHITELINE® Ceiling Tiles
- SQUARELINE® Metal Ceiling Tiles
- BIOLINE® Wood Ceiling Tiles
- SONEX® Baffles and Panels
- SONEX Clean Baffles, Panels and Ceiling Tiles
- FABRITEC Wall Panels
- PHONSTOP™ Ceiling and Wall Tiles
- WHISPERWAVE™ Panels, Baffles, Ceiling Clouds and Awnings
- PROSPEC® Barriers, Foams and Composites
- PROSPEC Decibel Drop™ Viscoelastic Damping Compound
- pinta Ceiling Grid Systems